



**Meter   Mix   Dispense**

PRECISION | RELIABILITY | DURABILITY



PROGRESSING  
CAVITY PUMPS



Fluid Research Corporation (FRC) progressing cavity metering pumps deliver precise, consistent and reliable dispensing of a wide variety of fluid media. Accurate precision dispensing is achieved independent of media viscosity. FRC pumps exhibit exceptional resistance to abrasive/filled content and chemically aggressive fluids. Suitable for single or multi-component applications, FRC pumps are precision made in the USA.

Fluid Research has been the North American authority on progressing cavity metering and proportioning pumps for more than fifteen years. These true positive displacement pumps transfer fluid by means of the progress, through the pump, of a sequence of small, fixed sized, discrete cavities, as a rotor turns within an elastomeric stator. This design creates sealed cavities maintaining precise fluid delivery with each rotor turn. Operational advantages include constant volume at variable speeds, continuous flow, few moving parts, low maintenance and no cycle time delays for cavity recharge.

Specific design features of progressing cavity pumps provide additional functional benefits. The cavities taper down toward their ends and overlap with their neighbors, essentially eliminating flow pulsation. No flow meter or check valves are required due to the seal design of progressing cavity pumps.

FRC progressing cavity pumps are ideal for food, pharmaceutical, and industrial applications.

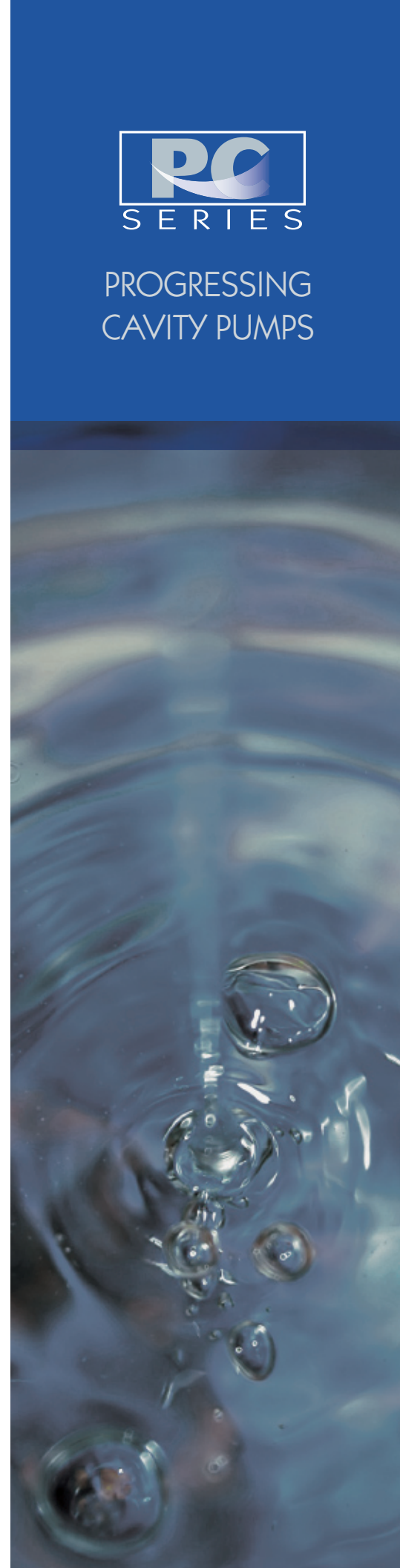

#### **FRC PROGRESSING CAVITY STANDARD FEATURES:**

- Hard chromed rotor
- Tri-clamp inlet
- Pressure transducer port (M-style only)
- Double lip seal
- Sealed bearings
- Corrosion resistant construction
- Easy assembly/disassembly

## *Accurate and Efficient Delivery of Both High and Low Viscosity Materials*

FRC progressing cavity pumps are ideal for precision pumping and difficult material handling requirements. FRC's valveless technology features excellent repeatability and can dispense dots and beads even at a change of speed.

FRC's easily installed progressing cavity pumps have a lower initial investment, which when combined with low maintenance, translate to a better bottom line. FRC's parts and service availability means fast delivery and less downtime. FRC's pumps convey highly viscous

materials reliably and accurately, and reduce clean-up time, manual material handling, and potential health and safety hazards.



*Fluid Research  
M-Style Pumps*

#### **Top 10 FRC Progressing Cavity Pump Benefits:**

- Smooth, pulsation-free delivery of viscous products
- Manage filled materials with ease
- Ideal for shear sensitive materials
- Reversible – no dripping or stringing
- Easy to disassemble, clean and maintain
- Extremely accurate metered flow
- Gentle on product
- Self-priming
- Reliable
- Made in the U.S.A.

## Intelligent Conveyance

FRC's M-Style pumps are designed for industrial single-component and proportioning embedded pumping systems. The AD-style pumps are ideal for primarily single-component robotics end effector use, pharmaceutical, and food applications. FRC's progressing cavity pumps offer up to 17.4 gallons per hour output and pressure capacities to 360 psi. Normal operating parameters range from 10 degrees to 100 degrees Celsius and supply (input) pressure up to 150 psi.

FRC PUMP MODELS					
FRC MODEL #	GPM 200 RPM	CC/MIN 200 RPM	Dimensions INCHES	Weight LBS.	Conveying Pressure
M-4-0.3	0.015	58	14.3 LOA 2.0 Dia	4.5	360 psi
M-4-0.5	0.030	112	14.3 LOA 2.0 Dia	4.5	360 psi
M-4-1.5	0.085	320	17.37 LOA 2.0 Dia	5.1	360 psi
M-4-3.0	0.159	600	20.5 LOA 2.5 Dia	8.0	360 psi
M-4-6.0	0.317	1200	22.0 LOA 2.5 Dia	8.4	360 psi
AD-4-0.3	0.015	58	13.0 LOA 2.0 Dia	4.2	360 psi
AD-4-0.5	0.030	112	13.0 LOA 2.0 Dia	4.2	360 psi
AD-4-1.5	0.085	320	16.0 LOA 2.0 Dia	4.8	360 psi

### FRC Progressing Cavity Pumps May be Used to Transfer Materials Such as:

- Abrasive filled polymers
- Microsphere filled polymers
- Thixotropic materials
- Most anaerobic adhesives & sealants
- Silicones, epoxies, lubricants & polyurethanes
- Pastes, paints & gels
- Cosmetics and pharmaceuticals
- Food products
- And more

Fluid Research  
AD-Style Pumps

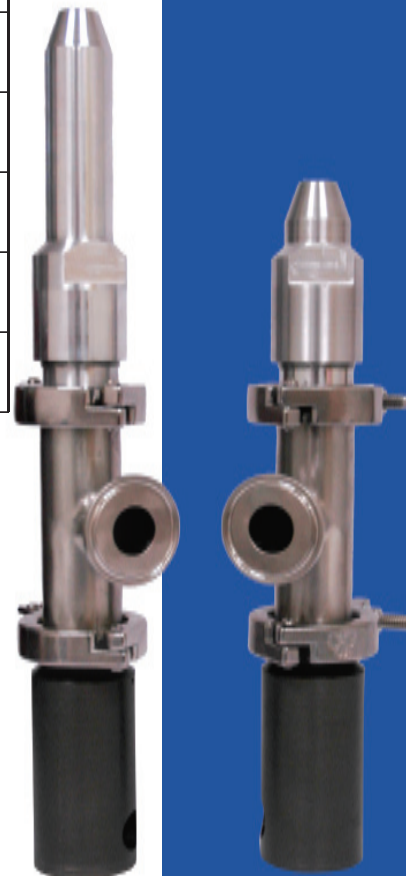

### FRC PROGRESSING CAVITY OPTIONS:

- Stainless steel components
- Heated jacket to warm material conveyed
- Suction port may be rotated to any position
- Stator materials: EPDM, Aflas, Viton and, other materials upon request
- Food grade materials
- Choice of mounting flange

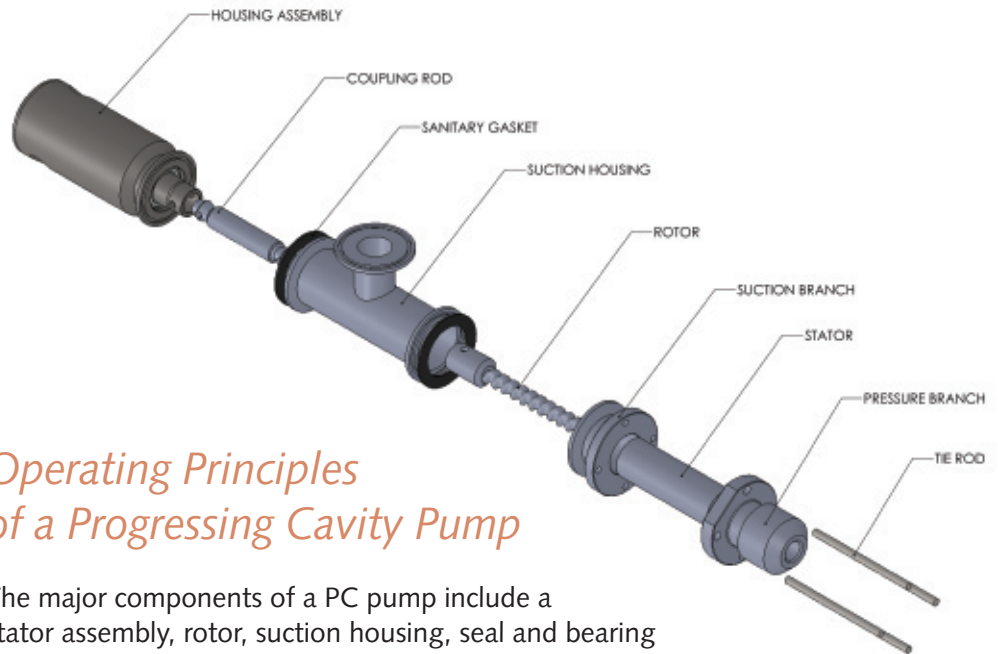

## *Operating Principles of a Progressing Cavity Pump*

The major components of a PC pump include a stator assembly, rotor, suction housing, seal and bearing assembly, and a coupling rod. FRC PC pumps feature a single rotating assembly. Each turn of the rotor dispenses a precise amount of material, either in doses or continuously, and accuracy is generally unaffected by viscosity or density.

The stator assembly is a hollow metal jacketed elastomeric tube with a double helical passage through the center. The rotor is a single helical rod which closely fits within the stator, forming separate sealed cavities along the entire length of the assembly. Rotational motion of the rotor is provided through the seal and bearing assembly and through the suction housing by an articulated coupling rod. As the rotor turns, sealed cavities progress from the entrance of the stator and exit at the discharge side. FRC PC pumps are identified by the amount of material discharged per one full revolution.

Due to the rolling nature of the engagement between the rotor and stator, abrasive materials cause significantly less wear on wetted components. Reliability and life are greater than any other known metering solution.

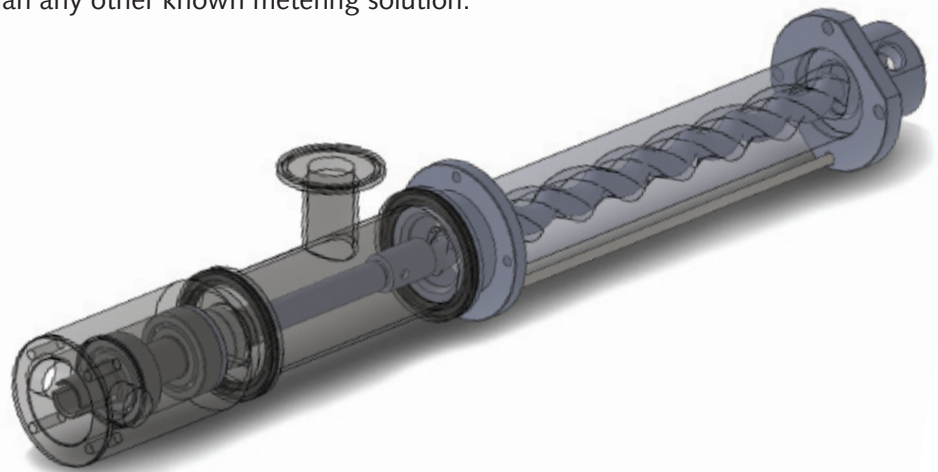

PCP0611