

Pump Model M-4-1.5



Overview

FRC's M style pumps provide the highest precision accuracy and reliability in delivering small quantities. The pumps are ideal for use in food and pharmaceutical applications as well as industrial single component media in automation and robotic delivery systems.

This precision FRC pump delivers small quantities of material accurately, consistently and reliably. It is particularly suited for low to high viscosity media, abrasive media and chemically aggressive media. All delivered free of pulsation with very low shear due to the progressing cavity rotor-stator design and function.

Applications

- Dots, beads, lines, filling, metering, encapsulating or gasketing (no auxiliary dispense valve needed)
- Most epoxies, silicones, urethanes, sealants and adhesives
- Also preferred for slurries, pastes and syrups in food and pharmaceutical industries
- Low to high viscosity materials
- Abrasive and chemically aggressive media

Technical Specifications

Displacement Volume	1.60	ml per revolution
Max Flow Rate	320	ml per min @ 200 rpm
Min Flow Rate	16	ml per min @ 10 rpm
Minimum Dispense Quantity	0.40	ml
Operation Temperature	32 to 180	degrees F
Material Temperature	32 to 180	degrees F
Maximum Dispense Pressure	360	psi
Supply (input) Pressure	-5 to 150	psi
Retained Volume	100	ml
Inlet	1 1/2	tri-clamp
Outlet	9/16 - 18	
Weight	5.1	lbs.

Dimensions

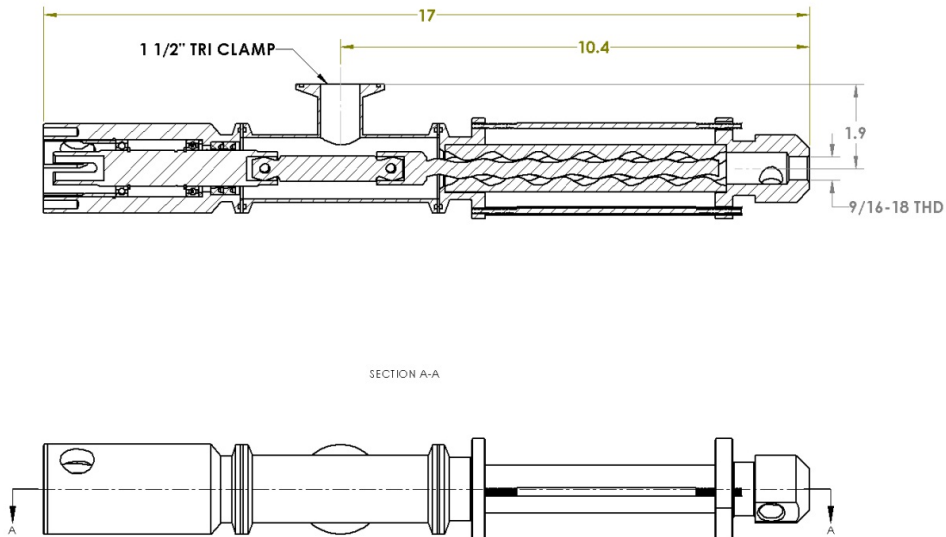

3D Isometric View

